



wattbike

NUCLEUS



QUICK START GUIDE

WELCOME TO
THE TRIBE

#WATTBIKERS

WELCOME TO YOUR WATTBIKE NUCLEUS

THE EVOLUTION
OF A PIONEER

This guide will show you how to build and set up your Nucleus, how to connect to your preferred devices and how to get the most from your Nucleus' features.



01 IN THE BOX

- Wattbike Nucleus
- Wattbike Performance Touchscreen
- Power Adaptor
- Combination Pedals
- Quick Start Guide
- Allen Keys
- Spanner

02 SPECIFICATION

BIKE WEIGHT	55kg
BIKE FOOTPRINT	Floor space= 125 x 66cm Footprint inc tablet = 145 x 66cm
MAX RIDER WEIGHT	150kg (23st, 81b)
MIN - MAX RIDER HEIGHT	150cm - 195cm (4'11" - 6'5")
RESISTANCE TYPE	Dual - air and magnetic
POWER RANGE	0-2000W
PEDALS	Combination pedals fitted as standard
WIRELESS TECHNOLOGIES	Wi-Fi, Bluetooth, NFC, ANT (Heart Rate Only), ANT+, Polar (Heart Rate Only)
COMPATIBLE HR DEVICES	BLE, ANT+, ANT (Suunto), Polar



03 FEATURES

WATTBIKE
PERFORMANCE
TOUCHSCREEN,
WI-FI, BLUETOOTH,
NFC, ANT+ AND
ANT COMPATIBILITY

PERFORMANCE
TOUCHSCREEN
ANGLE
ADJUSTMENT

HORIZONTAL
HANDLEBAR
ADJUSTMENT

BOTTLE CAGE

ADJUSTABLE
HANDLEBAR
HEIGHT

MAGNETIC
RESISTANCE

AIR RESISTANCE
0-2000W
+/-2% ACCURACY

TRANSPORTATION
ROLLERS

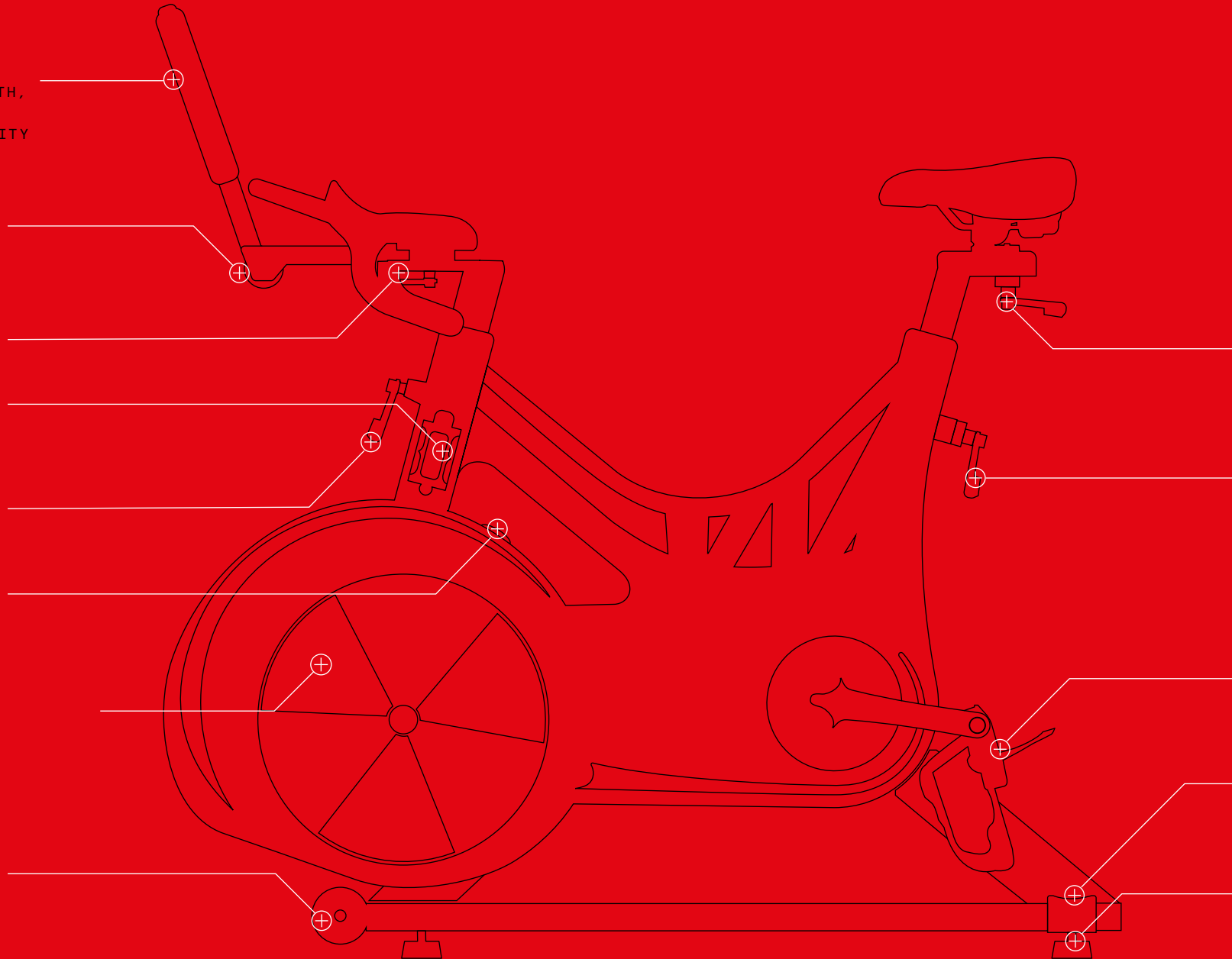

HORIZONTAL
SADDLE
ADJUSTMENT

ADJUSTABLE
SADDLE
HEIGHT

COMBINATION
PEDALS

STRETCHING
BUMPERS

LEVELLING
FEET

04 GET READY TO RIDE

If you have ordered your bike as a boxed delivery, please carefully follow the instructions below to ensure safe use following the build.

BUILD

- 1 Remove all parts from the box and dispose of the packaging. Keep the cardboard block, which you can use to stabilise the frame.

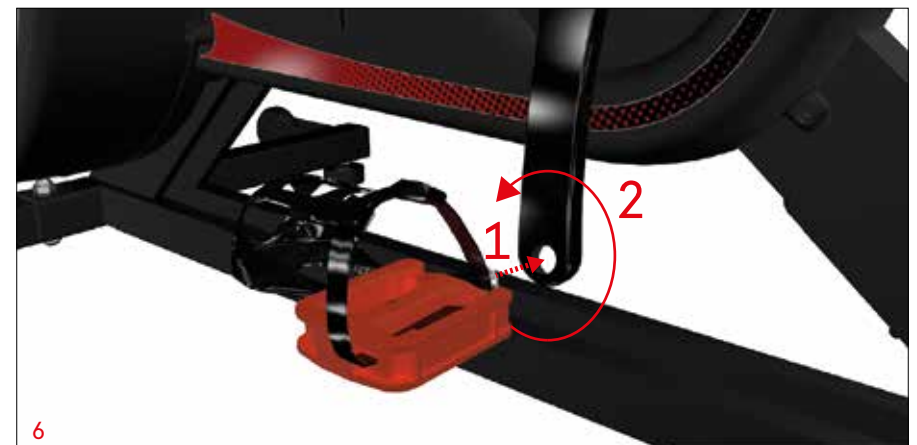
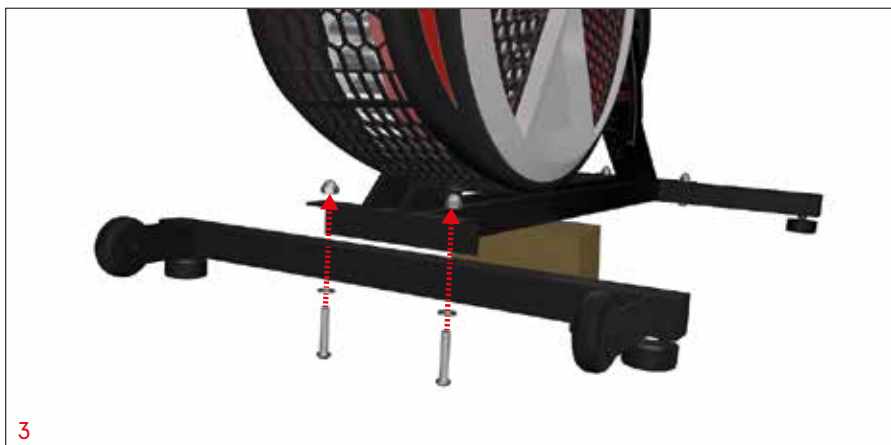
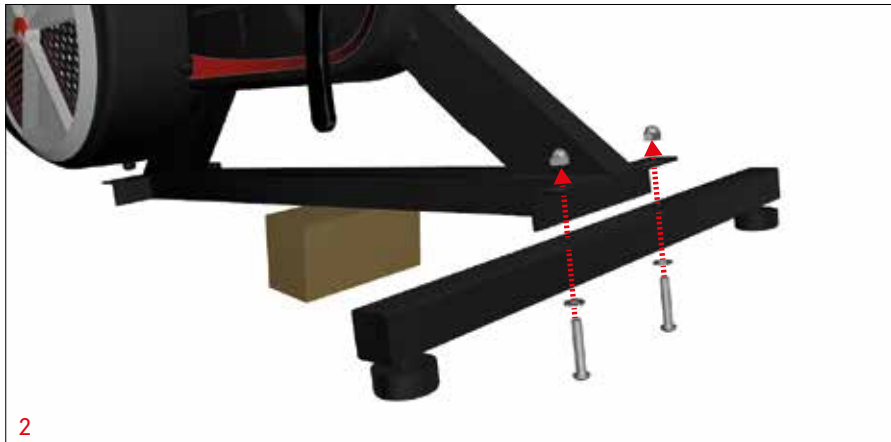

Warning: Please ensure pedals are tightened thoroughly to avoid damage to the bike or injury to the user. We advise that you periodically check the tightness as pedals may loosen over time with use.

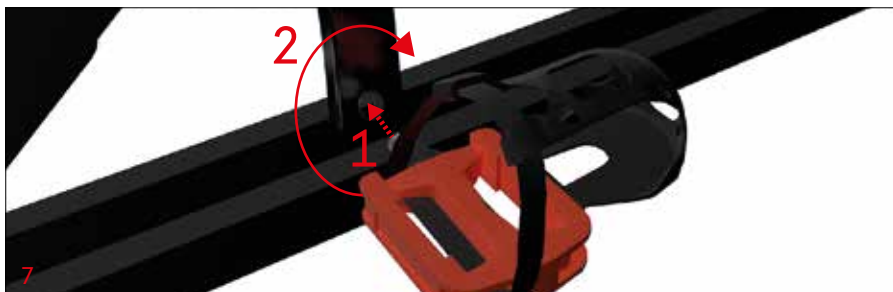

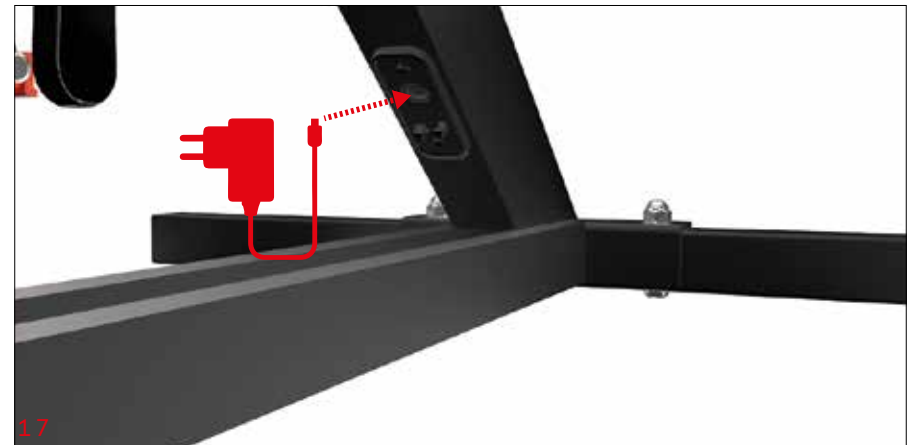
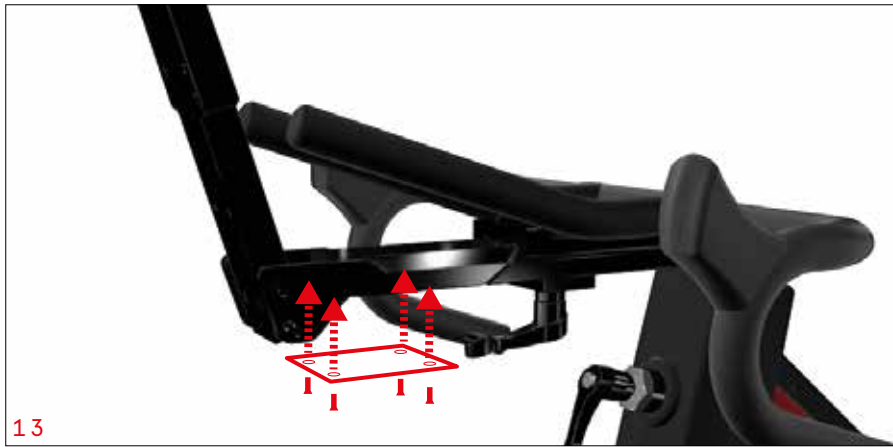

SET UP

The Wattbike Nucleus can accommodate any rider through our unique real ride setup. Use the corresponding adjustment levers to manipulate the saddle and handlebar positions to get the right fit for your members and clients.

STEP 1: SETTING THE SADDLE HEIGHT



STEP 2: SETTING THE SADDLE HORIZONTAL POSITION



STEP 3: SETTING THE HANDLEBAR POSITION



Alternatively, visit wattbike.com/GB/bike-fit to accurately replicate real ride bike figures and positioning onto the Nucleus.

BIKE FIT

01 BEFORE YOU START

02 TAKING MEASUREMENTS

01 Draw a plumb line down from the saddle at its widest width to the tape measure on the floor. The measurement at which the plumb line intersects the tape measure is A_1 .

A_1 :"



05 PERFORMANCE TOUCHSCREEN

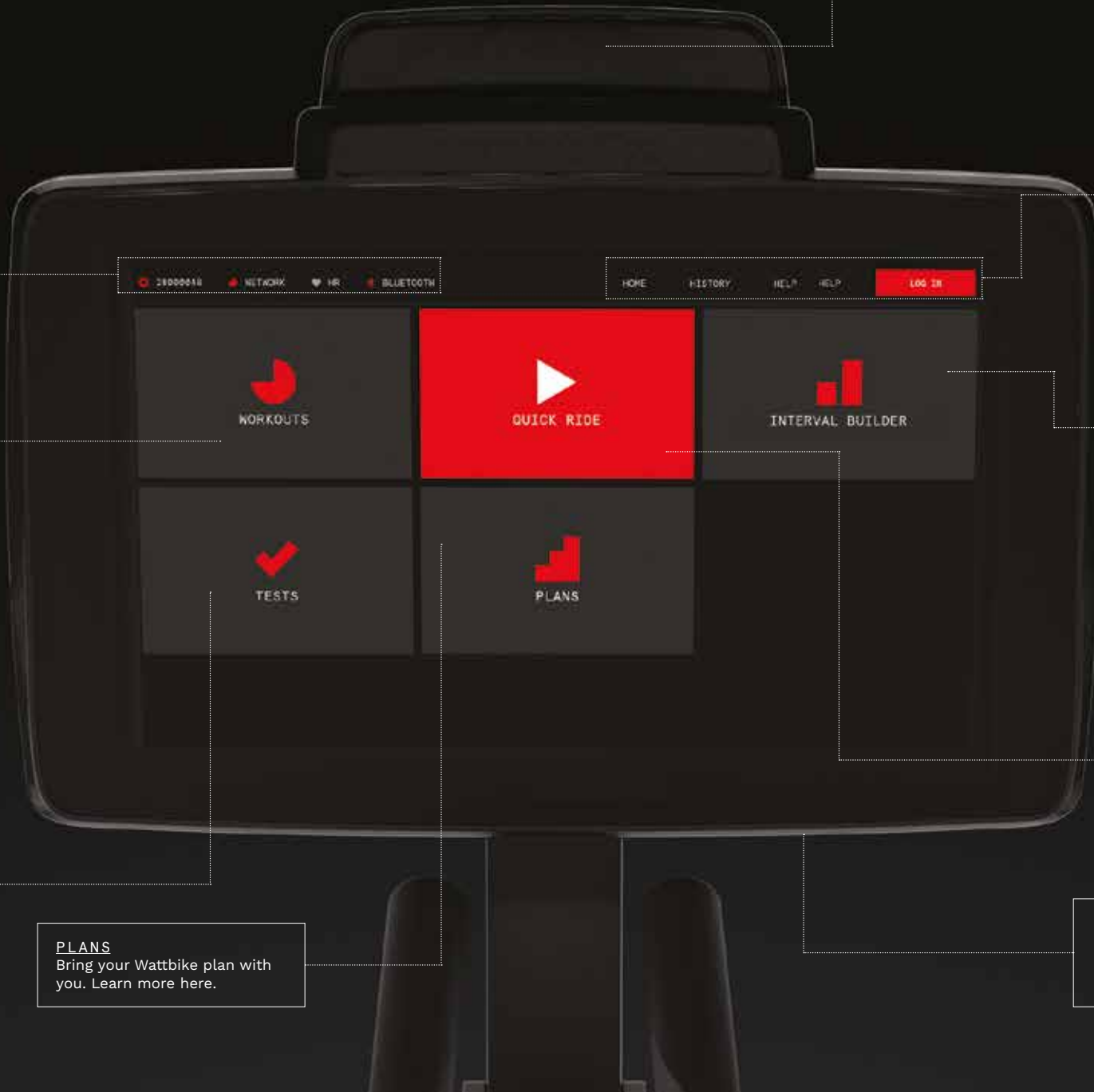

SERIAL NUMBER

Use this ID when connecting third-party apps. Click for bike information and advanced options.

NETWORK STATUS

For automatic updates and a fully connected user experience, ensure you are connected to a network.

HR

Train efficiently by connecting a heart rate monitor - simply tap the heart rate icon to do so.

BLUETOOTH

See how to connect to Wattbike Hub and third-party apps.

WORKOUTS

Access the world's best workouts. Categories include Endurance, Speed, HIIT and Cycling Simulations.

TESTS

Track, benchmark and analyse performance with Wattbike's accurate tests.

PLANS

Bring your Wattbike plan with you. Learn more here.

DEVICE HOLDER

HOME
Touch 'HOME' to return to the home screen.

HISTORY
Access session history, save workouts to your Wattbike Hub account, and keep track of usage here.

HELP
Access FAQs and tips regarding your Wattbike Nucleus.

LOG IN
Log in to a Wattbike Hub account for a more personalised experience and to save sessions.

INTERVAL BUILDER
Allow your clients and members to build their own custom interval workouts with this tool.

POWER BUTTON

QUICK RIDE
Don't want to follow a specific workout? Start an open session here.

PORTS
HDMI port, 1 micro USB for maintenance and diagnostics, USB port for device charging, audio jack.

06 GET CONNECTED

LINKING UP A HEART RATE SENSOR

The Wattbike Nucleus is compatible with all popular HR belts, and can be synced up either before or during a session. Simply tap the HR icon at the top of the screen to link up at any time.

CONNECTING TO THIRD PARTY APPS

Your Nucleus can connect to third party training apps such as The Sufferfest, Zwift and TrainerRoad through your phone or tablet. To do this, follow the below steps:

1. Enable Bluetooth or ANT+ on your device (phone, tablet or computer)
2. Open your preferred training app and navigate to the point of connecting your indoor trainer
3. Select the ID shown in the top left corner of the Performance Touchscreen, for example: 'WattbikeNucleus12345' or '12345'
4. The touchscreen will switch to a Quick Ride screen and display your Wattbike workout data
5. Wattbike workout data will be transmitted to your chosen third party app

You can connect to any training apps which support Bluetooth or ANT+*.



*To use third party apps, a mobile device needs to be connected to the Wattbike via Bluetooth or ANT+, and personal subscriptions to the app are also required.

CONNECTING TO A NETWORK

1. Swipe up from the bottom of the screen



2. Select the dot at the bottom of the screen



- 3 Select the 'Settings' icon then 'Wi-Fi settings'



- 4 Select and connect to your network

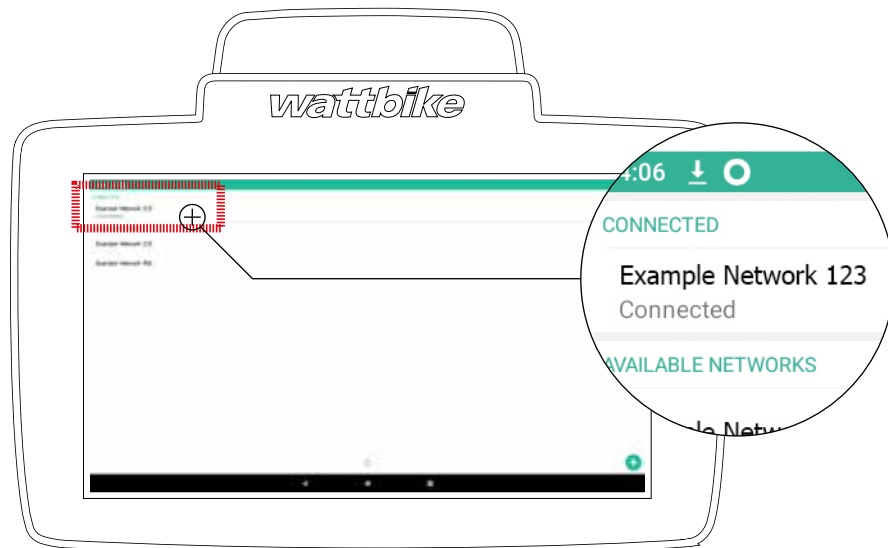

07 MAINTENANCE

AFTER EACH SESSION

To ensure your Nucleus stays in good condition use a clean, soft cloth and non-abrasive liquid cleaner after each session to remove all sweat, dust, dirt and other substances.

REGULAR MAINTENANCE

Where necessary:

- Vacuum the floor under and around the Nucleus to prevent dust ingress
- Inspect the saddle and handlebar stem adjustment levers. Tighten and grease as necessary
- Check that the pedals are secure and fit for use. Replace straps and pedals if necessary
- Ensure that no sweat/liquid is pooling on the metalwork or covers
- Ensure pedals are tightened thoroughly to avoid damage to the bike or injury to the user. We advise that you periodically check the tightness as pedals may loosen over time with use.

ADDITIONAL RESOURCES

For more information and full set up guides, visit the support section of wattbike.com





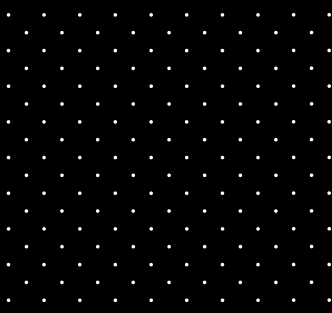

N

